

Rotating cleaners - Clipdisc 150

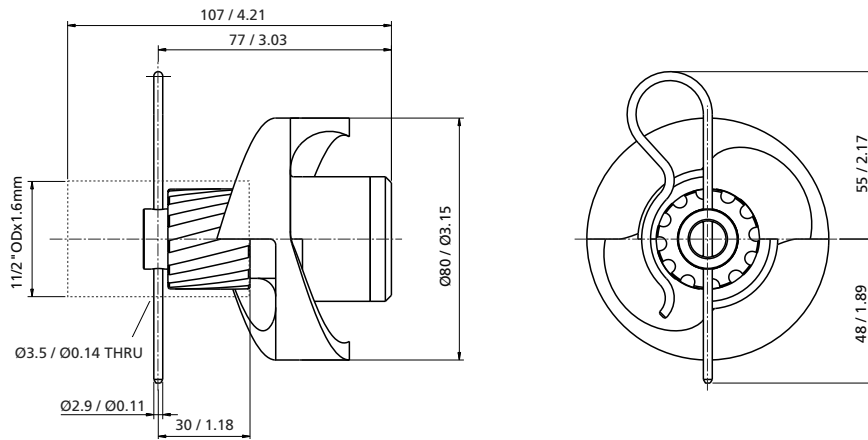

Photo shows cleaner with optional fixing tube

- High rotation speed
- Ultrahygienic
- Good rinsing performance

Clipdisc 150	
Working pressure:	2 - 4 bar (29 - 58 psi)
Cleaning diameter:	max. 4.9 m (16 ft)
Flow rate:	11 - 15.8 m ³ /h (183 - 263 l/min / 48.3 - 69.5 USgpm)
Spray angle:	360°
Operating temperature:	max. 95 °C (203 °F)
Ambient temperature:	max. 140 °C (284 °F), 30 min
Insertion opening:	min. Ø 110 mm (4.33 inch)
Materials:	stainless steel 316L (1.4404) with PVDF
Preferred mounting position:	any

Version	Part number
Pin Fix for 1 1/2" OD pipe (38.1x1.6 mm)	4660-1303-517



Dimensions (mm / inch)

